



# 90W

INDUCTION MOTOR, REVERSIBLE MOTOR  
 □ 90mm TERMINAL BOX TYPE

## INDUCTION MOTOR - CONTINUOUS RATING

SIZE mm sq.	Type	Poles	Output (W)	Voltage (V)	Frequency (Hz)	Duty	Rated Load				Starting (kg-cm)	Torque (N-m)	Capacitor (uF)
							Current (A)	Speed (rpm)	Torque (kg-cm) (N-m)				
90	S9190GA( )-T S9190GA( )-T1	4	90	1 ∅ 110	60	Cont.	2.00	1600	5.60	0.560	5.70	0.570	25.0
	S9190GB( )-T S9190GB( )-T1	4	90	1 ∅ 220	60	Cont.	1.00	1600	5.60	0.560	5.70	0.570	6.0
	S9190GC( )-T S9190GC( )-T1	4	90	1 ∅ 100	50 60	Cont.	1.80 2.00	1300 1550	6.90 5.80	0.690 0.580	5.00	0.500	25.0
	S9190GD( )-T S9190GD( )-T1	4	90	1 ∅ 200	50 60	Cont.	0.90 1.00	1300 1550	6.90 5.80	0.690 0.580	5.00	0.500	6.0
	S9190GX( )-T S9190GX( )-T1 S9190GX( )-TCE S9190GX( )-T1CE	4	90	1 ∅ 220 1 ∅ 240	50	Cont.	0.68 0.72	1300	6.90 7.20	0.690 0.720	4.80 5.20	0.480 0.520	5.0
	S9190GU( )-T S9190GU( )-T1 S9190GU( )-TCE S9190GU( )-T1CE	4	90	3 ∅ 200	50 60	Cont.	0.63 0.60	1300 1550	6.90 6.00	0.690 0.600	10.60 8.90	1.060 0.890	—
	S9190GT( )-T S9190GT( )-T1 S9190GT( )-TCE S9190GT( )-T1CE	4	90	3 ∅ 220	50 60	Cont.	0.68 0.55	1350 1600	6.80 5.70	0.680 0.570	13.00 10.50	1.300 1.050	—
	S9190GS( )-T S9190GS( )-T1 S9190GS( )-TCE S9190GS( )-T1CE	4	90	3 ∅ 380	50	Cont.	0.32	1300	6.80	0.680	10.55	1.055	—
					60		0.30	1550	5.70	0.570	8.20	0.820	
					50	Cont.	0.35	1300	6.90	0.690	11.70	1.170	
					60		0.32	1550	5.80	0.580	8.90	0.890	
					50	Cont.	0.33	1350	6.80	0.680	12.00	1.200	
					60		0.29	1600	5.70	0.570	9.50	0.950	
	50	Cont.	0.35	1350	6.90	0.690	13.30	1.330					
	60		0.31	1600	5.80	0.580	10.50	1.050					

- ❖ CE marked at the end of the model name indicates that it is thermally protected type which has received CE with built-in TP.
- ❖ TP marked at the end of the model name indicates that it is standard motor with Thermal Protector mounted.  
 S9140GX, S9140GX-T, S9140GS-T is thermally protected type with TP mounted.
- ❖ ( ) is for marking 'L' type or 'H'. 'L' should be used with gearhead 'L' and 'H' should be used with gearhead 'H'.
- ❖ For a three-phase 380V~440V motor, be cautious when using the inverter. When inverter is used, the insulation of winding becomes hot and may cause damage to motor.

## REVERSIBLE MOTOR-30MINUTES RATING

SIZE mm sq.	Type	Poles	Output (W)	Voltage (V)	Frequency (Hz)	Duty	Rated Load				Starting Torque		Capacitor (uF)
							Current (A)	Speed (rpm)	Torque (kg-cm) (N-m)		(kg-cm)	(N-m)	
90	S9R90GA(-T) S9R90GA(-T1) S9R90GA(-T1(TP)) S9R90GA(-T1(TP)) S9R90GA(-TCE) S9R90GA(-T1CE)	4	90	1 ∅ 110	60	30min.	2.25	1550	5.80	0.580	8.50	0.850	30.0
	S9R90GB(-T) S9R90GB(-T1) S9R90GB(-T1(TP)) S9R90GB(-T1(TP)) S9R90GB(-TCE) S9R90GB(-T1CE)	4	90	1 ∅ 220	60	30min.	1.00	1550	5.80	0.580	8.50	0.850	7.0
	S9R90GC(-T) S9R90GC(-T1) S9R90GC(-T1(TP)) S9R90GC(-T1(TP)) S9R90GC(-TCE) S9R90GC(-T1CE)	4	90	1 ∅ 100	50	30min.	2.10	1200	7.50	0.750	6.50	0.650	30.0
	60				2.25		1500	6.00	0.600				
	S9R90GD(-T) S9R90GD(-T1) S9R90GD(-T1(TP)) S9R90GD(-T1(TP)) S9R90GD(-TCE) S9R90GD(-T1CE)	4	90	1 ∅ 200	50	30min.	0.90	1200	7.50	0.750	6.50	0.650	7.0
	60				1.00		1500	6.00	0.600				
	S9R90GE(-T) S9R90GE(-T1) S9R90GE(-TCE) S9R90GE(-T1CE)	4	90	1 ∅ 100	50	30min.	1.80	1200	7.50	0.750	6.50	0.650	30.0
	60				1.90		1500	6.00	0.600				
	S9R90GE(-T) S9R90GE(-T1) S9R90GE(-TCE) S9R90GE(-T1CE)	4	90	1 ∅ 115	60	30min.	1.80	1550	6.00	0.600	8.00	0.800	25.0
	S9R90GX(-T) S9R90GX(-T1) S9R90GX(-TCE) S9R90GX(-T1CE)				4		90	1 ∅ 220	50	30min.	0.82	1250	7.20
	1 ∅ 240	0.86	7.40	0.740		8.00		0.800					

- ❖ Appropriate capacitors shall be used according to the voltage for S9R60GE-T type since the size of the capacitor differs by different voltages. Malfunction may occur when not used properly. Capacitor for 115V will be delivered otherwise the required voltage is informed.
- ❖ CE marked at the end of the model name indicates that it is thermally protected type which has received CE. S9R60GE-TCE is available only for 115V specification.
- ❖ TP marked at the end of the model name indicates that it is standard motor with Thermal Protector mounted. S9R60GE-T, S9R60GX-T is thermally protected type with TP mounted.
- ❖ Above data is measured with friction brake mounted.
- ❖ ( ) is for marking 'L' type or 'H'. 'L' should be used with gearhead 'L' and 'H' should be used with gearhead 'H'.

## 50Hz

GEAR RATIO	3	3.6	5	6	7.5	9	10	12.5	15	18	20	25	30	36	40	50	60	75	90	100	120	150	180	200
	MODEL rpm	500	416	300	250	200	166	150	120	100	83	75	60	50	41	37	30	25	20	16	15	12	10	8
S9KC□B( )	kg-cm	18.2	21.9	30.4	36.5	45.6	54.7	60.8	68.4	82.1	98.6	110	124	149	178	198	200	200	200	200	200	200	200	200
S9KC□B( )-S	N·m	1.784	2.146	2.979	3.577	4.469	5.361	5.958	6.703	8.046	9.663	10.78	12.15	14.60	17.44	19.40	19.60	19.60	19.60	19.60	19.60	19.60	19.60	19.60

## 60Hz

GEAR RATIO	3	3.6	5	6	7.5	9	10	12.5	15	18	20	25	30	36	40	50	60	75	90	100	120	150	180	200
	MODEL rpm	600	500	360	300	240	200	180	144	120	100	90	72	60	50	45	36	30	24	20	18	15	12	10
S9KC□B( )	kg-cm	14.6	17.5	24.3	29.2	36.5	43.7	48.6	54.8	65.7	78.8	87.6	99.0	119	143	158	198	200	200	200	200	200	200	200
S9KC□B( )-S	N·m	1.431	1.715	2.381	2.862	3.577	4.675	4.763	5.370	6.439	7.722	8.585	9.702	11.66	14.01	15.48	19.40	19.60	19.60	19.60	19.60	19.60	19.60	19.60

- ❖ The code in □ of gearhead model is for gear ratio.
- ❖ It is the permissible torque of the assembled motor and gearhead.
- ❖ The permissible torque of the motor and inter-decimal gearhead is 200 kg-cm.
- ❖ ■ color indicates that the output shaft of the geared motor rotates in the same direction as the output shaft of the motor. Others indicate rotation in the opposite direction.
- ❖ Rpm is based on synchronous speed (50Hz: 1500rpm, 60Hz: 1800rpm) divided by gear ratio. The actual rotation speed can be 2~20% less than displayed value depending on the load.
- ❖ ( ) is for marking 'L' type or 'H'. 'L' should be used with motor 'L' and 'H' should be used with motor 'H'.

# DIMENSIONS

## + GEARED MOTOR

\* MOTOR MODEL : S9(I,R)90□□-T  
 \* HEAD MODEL : S9□C3B□-S~S9□C200B□-S

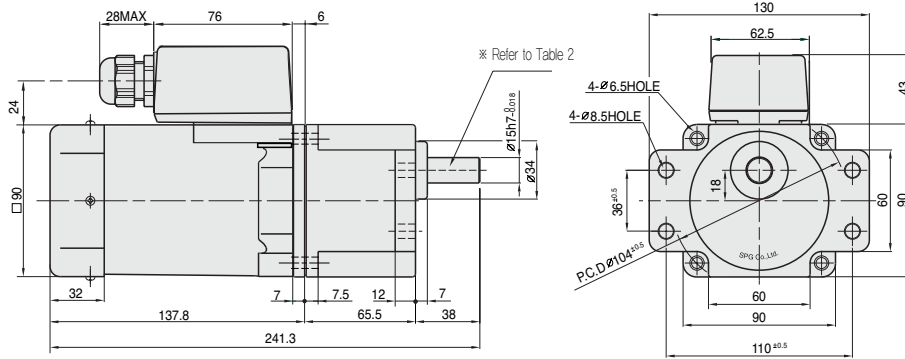

\* HEAD MODEL □ : S9□C3B□~S9□C200B□

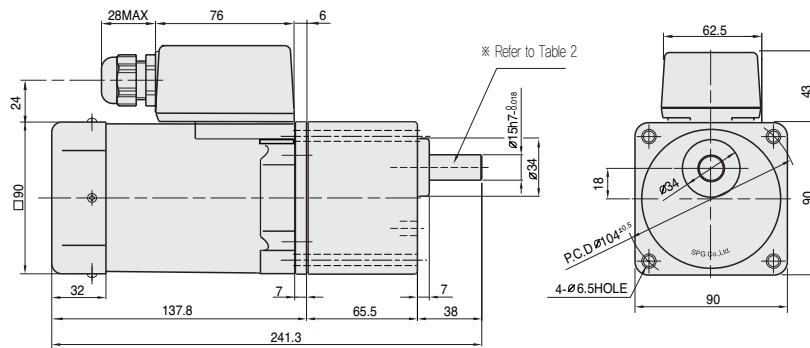

## + MOTOR

\* MOTOR MODEL : S9(I,R)90□□□-T

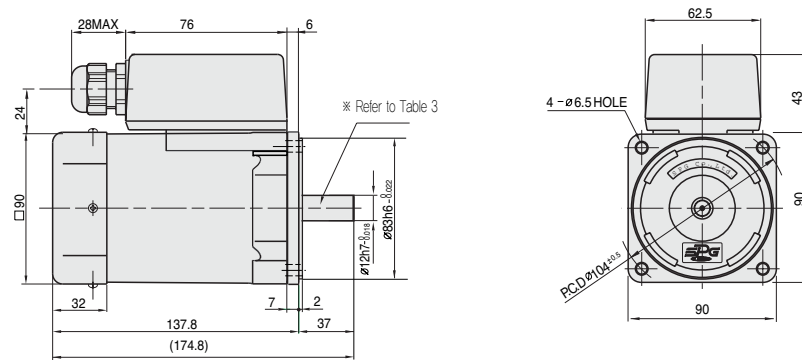

## + INTER-DECIMAL GEAR HEAD

\* MODEL : S9GX10B(H,L)-S

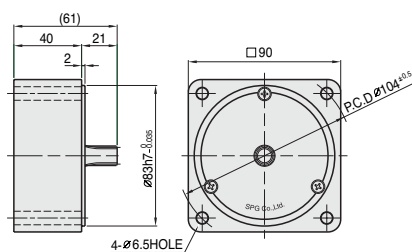

## + WEIGHT - (Table 1)

PART	WEIGHT(kg)	
MOTOR	3.10	
REVERSIBLE MOTOR	3.15	
DECIMAL GEAR HEAD	0.65	
GEAR HEAD	S9□C3B□ ~S9□C10B□	1.21
	S9□C12.5B□ ~S9□C20B□	1.30
	S9□C25B□ ~S9□C60B□	1.40
	S9□C75B□ ~S9□C200B□	1.45

# DIMENSIONS

## + GEARED MOTOR

- \* MOTOR MODEL : S9(I,R)90G□□-T1
- \* HEAD MODEL : S9□C3B□-S~S9□C200B□-S

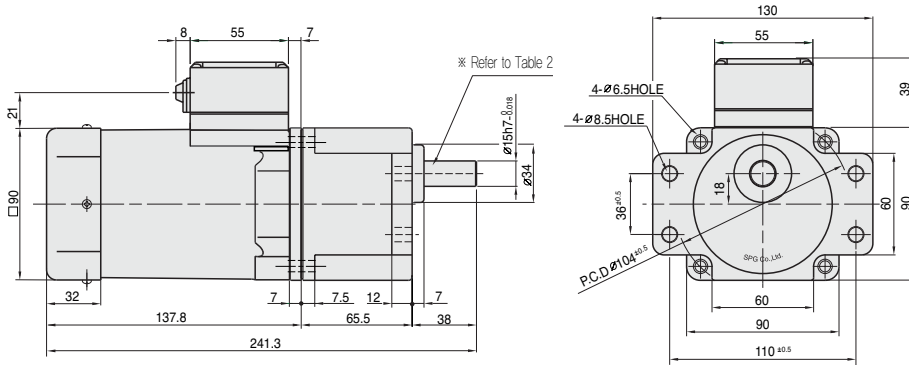

- \* HEAD MODEL : S9□C3B□~S9□C200B□

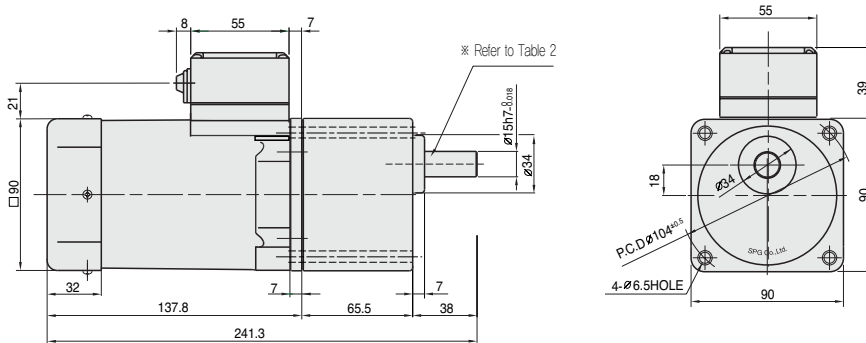

## + MOTOR

- \* MOTOR MODEL : S9(I,R)90□□□-T1

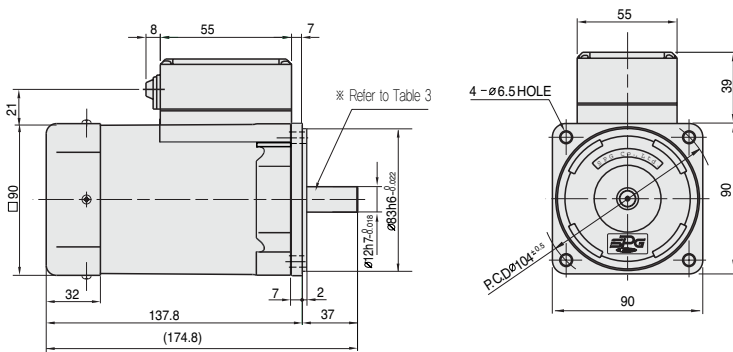

## + INTER-DECIMAL GEAR HEAD

- \* MODEL : S9GX10B(H,L)-S

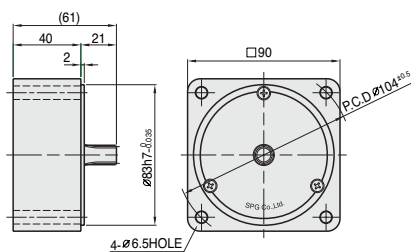

## + WEIGHT - (Table 1)

PART	WEIGHT(kg)	
MOTOR	3,05	
REVERSIBLE MOTOR	3,10	
DECIMAL GEAR HEAD	0,65	
GEAR HEAD	S9□C3B□ ~S9□C10B□	1,21
	S9□C12.5B□ ~S9□C20B□	1,30
	S9□C25B□ ~S9□C60B□	1,40
	S9□C75B□ ~S9□C200B□	1,45

## + KEY SPEC

GEAR HEAD	MOTOR

## + SPEC for output shaft of gearhead - (Table 2)

MODEL	TYPES OF OUTPUT SHAFT
STRAIGHT TYPE	
S9SC3B□ ~S9SC200B□	
D-CUT TYPE	
S9DC3B□ ~S9DC200B□	
KEY TYPE	
S9KC3B□ ~S9KC200B□	

## + SPEC for output shaft of motor - (Table 3)

MODEL	TYPES OF OUTPUT SHAFT
GEAR TYPE	
S9(I,R)90G□□-T S9(I,R)90G□□-T1	
STRAIGHT TYPE	
S9(I,R)90S□-T S9(I,R)90S□-T1	
D-CUT TYPE	
S9(I,R)90D□-T S9(I,R)90D□-T1	
KEY TYPE	
S9(I,R)90K□-T S9(I,R)90K□-T1	

## DIMENSIONS

### + GEARED MOTOR

※ MOTOR MODEL : S9(I,R)90□H-T  
 ※ HEAD MODEL : S9□D3B~S9□D200B

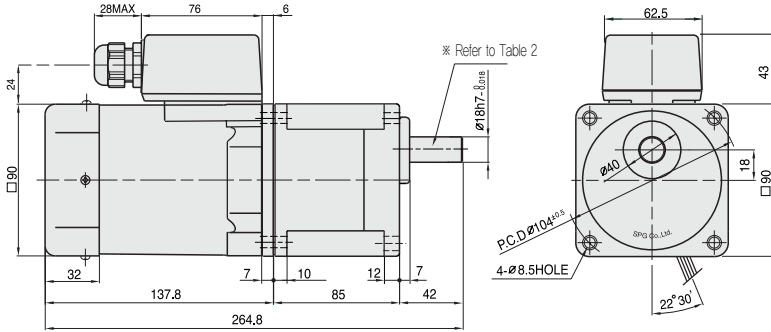

### + WEIGHT - (Table2)

PART		WEIGHT(kg)
MOTOR		3.10
GEAR HEAD	S9□D3B ~S9□D10B	1.65
	S9□D12.5B ~S9□D20B	1.80
	S9□D25B ~S9□D60B	1.90
	S9□D75B ~S9□D200B	1.95

### + KEY SPEC

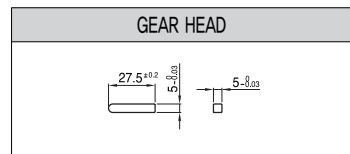

## DIMENSIONS

### + GEARED MOTOR

※ MOTOR MODEL : S9(I,R)90□H-T1  
 ※ HEAD MODEL : S9□D3B~S9□D200B

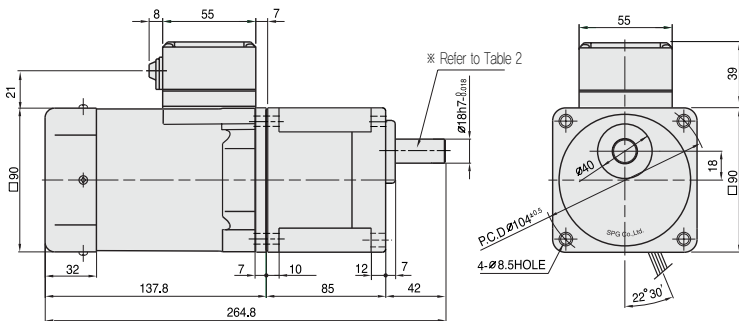

### + WEIGHT - (Table1)

PART		WEIGHT(kg)
MOTOR		3.05
GEAR HEAD	S9□D3B ~S9□D10B	1.65
	S9□D12.5B ~S9□D20B	1.80
	S9□D25B ~S9□D60B	1.90
	S9□D75B ~S9□D200B	1.95

### + KEY SPEC

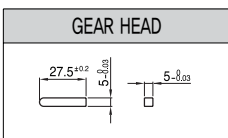

### + SPEC for output shaft of gearhead - (Table2)

MODEL	TYPES OF OUTPUT SHAF	MODEL	TYPES OF OUTPUT SHAF	MODEL	TYPES OF OUTPUT SHAF
S9SD3B ~S9SD200B	STRAIGHT TYPE 42 φ18	S9DD3B ~S9DD200B	D-CUT TYPE 42 25 17.5±0.2 φ18	S9KDB ~S9KD200B	KEY TYPE 42 27.5 φ18 5.75±0.05 25 3.78±0.1

### 50Hz

GEAR RATIO	3	3.6	5	6	7.5	9	10	12.5	15	18	20	25	30	36	40	50	60	75	90	100	120	150	180	200
	MODEL rpm	500	416	300	250	200	166	150	120	100	83	75	60	50	41	37	30	25	20	16	15	12	10	8
S9KD□B	kg-cm	18.2	21.9	30.4	36.5	45.6	54.7	60.8	68.4	82.1	98.6	110	124	149	178	198	248	297	300	300	300	300	300	300
	N·m	1.784	2.146	2.979	3.577	4.469	5.361	5.958	6.703	8.046	9.663	10.78	12.15	14.60	17.44	19.40	24.32	29.13	29.42	29.42	29.42	29.42	29.42	29.42

### 60Hz

GEAR RATIO	3	3.6	5	6	7.5	9	10	12.5	15	18	20	25	30	36	40	50	60	75	90	100	120	150	180	200
	MODEL rpm	600	500	360	300	240	200	180	144	120	100	90	72	60	50	45	36	30	24	20	18	15	12	10
S9KD□B	kg-cm	14.6	17.5	24.3	29.2	36.5	43.7	48.6	54.8	65.7	78.8	87.6	99.0	119	143	158	198	238	266	300	300	300	300	300
	N·m	1.431	1.715	2.381	2.862	3.577	4.675	4.763	5.370	6.439	7.722	8.585	9.702	11.66	14.01	15.48	19.40	23.34	26.09	29.42	29.42	29.42	29.42	29.42

- ❖ The code in □ of gearhead model is for gear ratio.
- ❖ It is the permissible torque (in small letters to be consistent with others) of the assembled motor and gearhead.
- ❖ The permissible torque of the motor and inter-decimal gearhead is 300 kg-cm.
- ❖ ■ color indicates that the output shaft of the geared motor rotates in the same direction as the output shaft of the motor. Others indicate rotation in the opposite direction.
- ❖ Rpm is based on synchronous speed (50Hz: 1500rpm, 60Hz: 1800rpm) divided by gear ratio. The actual rotation speed can be 2~20% less than displayed value depending on the load.
- ❖ Only "H" type is applicable. Please use "H" type motor.

## SCHEMATIC DIAGRAMS

The direction of motor rotation is as viewed from the front shaft end of the motor. Circled number is the terminal number inside terminal box.

### ■ INDUCTION MOTOR

S9190GA( )-T S9190GB( )-T S9190GC( )-T S9190GD( )-T S9190GA( )-T1S9190GB( )-T1 S9190GC( )-T1 S9190GD( )-T1		S9190GX( )-T S9190GX( )-TCE S9190GX( )-T1 S9190GX( )-T1CE		S9190GU( )-T S9190GT( )-T S9190GU( )-T1 S9190GT( )-T1		S9190GU( )-TCE S9190GU( )-T1CE		S9190GT( )-TCE S9190GT( )-T1CE	
CW		CCW		CW,CCW		CW		CCW	

### ■ REVERSIBLE MOTOR

S9190GS( )-TCE S9190GS( )-T S9190GS( )-T1CE S9190GS( )-T1		S9R90GA( )-T, S9R90GB( )-T S9R90GA( )-T1, S9R90GB( )-T1 S9R90GC( )-T, S9R90GD( )-T S9R90GC( )-T1, S9R90GD( )-T1		S9R90GX( )-T, S9R90GX( )-TCE S9R90GX( )-T1, S9R90GX( )-T1CE		S9R90GA( )-T(TP), S9R90GB( )-T(TP), S9R90GC( )-T(TP), S9R90GD( )-T(TP), S9R90GA( )-T1(TP), S9R90GB( )-T1(TP), S9R90GC( )-T1(TP), S9R90GD( )-T1(TP), S9R90GA( )-TCE, S9R90GB( )-TCE, S9R90GC( )-TCE S9R90GD( )-TCE, S9R90GE( )-T, S9R90GE( )-TCE S9R90GA( )-T1CE, S9R90GB( )-T1CE, S9R90GC( )-T1CE S9R90GD( )-T1CE, S9R90GE( )-T1, S9R90GE( )-T1CE	
CW		CCW		CW,CCW		CW,CCW	

Change the direction of motor rotation only after the motor stops completely. If an attempt is made to change the direction of rotation while the motor is running, the motor may ignore the reversing command or change its direction of rotation after some delay.